

## 5. 组合垫

### a 定义

组合垫由钢圈和橡胶圈粘合而成，能够对接头或螺帽有良好的密封性能。这种坚固的密封圈能够承受高压并且正在逐渐取代铜制密封圈。

### b 特性

#### √ 截面形式

为了满足标准化与安装的要求，Techné提供四种不同的截面形式：

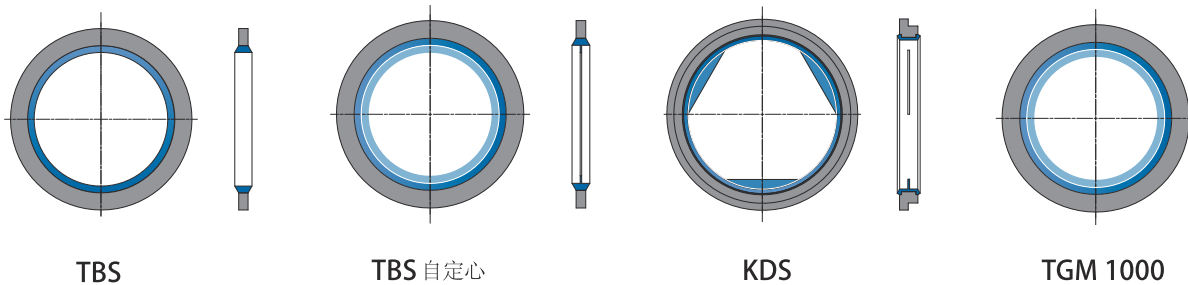

#### TBS

使用最广泛的组合密封圈，适用于所有类型的接头或螺帽：PSM，ISO，公制的和英制的。

#### 自动定心 TBS

与TBS组合密封圈相类似，具有一层能够确保密封圈与螺纹中心对准的橡胶薄层。由于其不会掉落特性，强力推荐用于需要垂直安装的应用中。

#### KDS

铰接式接头专业组合垫。橡胶具有很强的粘合力，金属部分经过热处理，抗压力强，推荐在高压下（600bar）使用这类密封圈。

#### TGM1000

与TBS密封圈类似，但是具有更好的抗压性。

## ✓ 金属材料的选择

组合垫的金属材料的选择是根据其所承受的压力和所处的环境而定，拉伸实验用来测试其抗压性。

钢	涂层 (ISO 4042)	拉伸强度	耐盐雾腐蚀性 (ISO 9227) <sup>1</sup>
DC01-270	Zn (5µm)	> 270 Mpa	300 h
	ZnNi (12µm)		720 h
DC01-590	Zn (5µm)	> 540 Mpa	300 h
	ZnNi (12µm)		720 h
不锈钢AISI 304	钝化	> 540 Mpa	500h
不锈钢AISI 316		> 540 Mpa	2000h
不锈钢 AISI 316 L		> 540 Mpa	>2000h

<sup>1</sup> 参数值

## ✓ 橡胶材料的选择

根据压力，环境和需要密封的液体，Techné提供不同的橡胶材料：

- NBR 80±5 IRHD
- HNBR 80±5 IRHD
- FKM 80±5 IRHD
- EPDM 80±5 IRHD

根据客户的要求，Techné能够提供不同的硬度：85或90IRHD。

## ✓ 安装

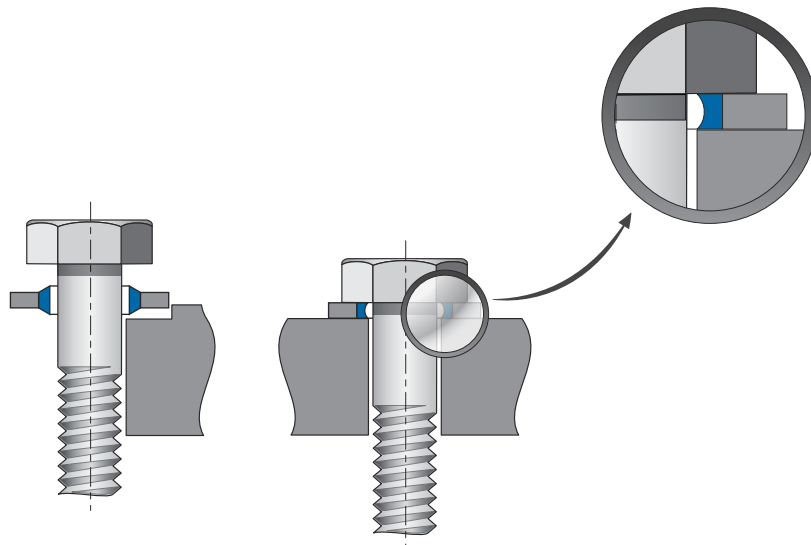

## √ 扭力

公制螺距	螺栓	BSP	力 (N.m)
≤ 8	5/16		5.3
10	3/8	1/8	7.1
11	7/16		11.8
12	1/2	1/4	15.8
14	9/16		22.6
16	5/8	3/8	30.5
18	3/4		40.7
20	13/16	1/2	56.5
22	7/8	5/8	67.8
24	1	3/4	73.4
≥ 27	1,1/16		79.0

## √ TBS系列

NBR 或 FKM 80±5 IRHD, DC01-270级的钢圈,  
根据客户要求, 其他材质也可供选择。

TBS与螺栓直径的标准相匹配

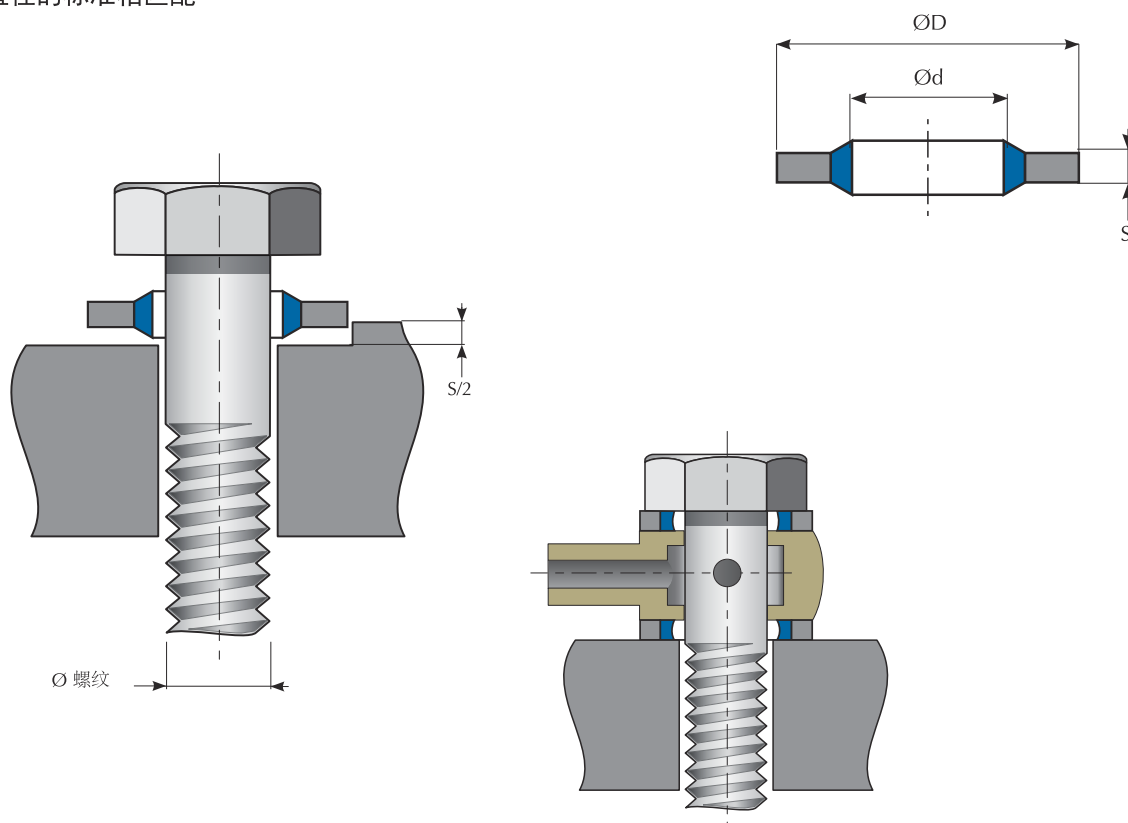

英制尺寸

NBR 80	FKM 80	BSP	螺纹	类型	d	D	S
03.0300.0006			6BA	001	3,05	6,35	1,20
03.0300.0007			4BA	002	4,12	7,26	1,20
03.0300.5284			2BA	003	5,21	8,38	1,20
03.0300.0072			1/4	005	6,99	13,34	1,20
03.0300.0341			5/16	006	8,31	13,34	1,20
03.0300.0065			5/16	007	8,64	14,22	1,20
03.0300.0115			40	008	11,26	18,36	2,00
03.0300.0120			7/16	009	11,69	19,05	2,00
03.0300.0150			9/16	010	14,86	22,23	2,00
03.0300.3002			11/16	011	16,51	25,40	2,00
03.0300.0180			11/16	012	18,16	25,40	2,30
03.0300.0210			15/16	013	24,26	33,27	2,30
03.0300.0243			1 1/8	014	29,33	36,58	2,30
03.0300.0252			1 1/4	015	32,64	41,40	3,20
03.0300.0270			1 3/8	016	35,94	44,45	3,20
03.0300.0275			1 1/2	017	38,96	47,75	3,20
03.0300.0280			1 3/4	018	45,34	57,15	3,20
03.0300.0295			2	019	51,69	63,50	3,20
03.0300.0100			3/8	020	10,37	15,88	2,00
03.0300.0140		1/4	1/2	021	13,74	20,57	2,00
03.0300.0155			60	022	15,83	22,23	2,00
03.0300.3000	03.0380.1725	3/8		023	17,28	23,80	2,00
03.0300.0190			3/4	024	19,69	26,92	2,30
03.0300.0200		1/2	13/16	025	21,54	28,58	2,50
03.0300.2154		1/2	13/16	(025)	21,54	28,58	2,00
03.0300.0209		5/8	7/8	026	23,49	31,75	2,30
03.0300.0225		3/4	1,00	027	27,05	34,93	2,50
03.0300.0014		1	3/4	(027)	27,05	34,93	2,30
03.0300.2784			1 1/16	028	27,82	38,61	2,30
03.0300.0245		7/8	1 3/16	029	30,81	38,10	2,30
03.0300.0260		1.0	1 5/16	030	33,89	42,80	3,20
03.0300.0255		1.0	1 5/16	031	33,89	42,80	2,30
03.0300.0292		1.1/4	1 5/8	032	42,93	52,38	3,20
03.0300.0285	03.0380.0011	1.1/2	1 7/8	033	48,44	58,60	3,20
03.0300.0298		1.3/4	2 1/8	034	54,89	69,85	3,20
03.0300.0299			2 1/4	035	58,04	70,36	3,20
03.0300.0300	03.0380.0010	2.0		036	60,58	73,03	3,20
03.0300.0310			2 1/2	037	64,39	77,72	3,20
03.0300.0315		2 + 1/4		038	66,68	79,50	3,20
03.0300.0325		2 + 1/2		039	76,08	90,17	3,4

非详尽清单，Techné提供所有特殊的英制尺寸。



## 公制尺寸

NBR 80	FKM 80	M	类型	d	D	S
03.0300.6711		M6	208	6,70	11,00	2,50
03.0300.0050		M6 (6,5)	209	7,10	12,00	1,00
03.0300.0073		M6 (6,7)	210	7,30	10,20	1,00
03.0300.0055	03.0380.8513	M8	211	8,50	13,40	1,00
03.0300.0080	03.0380.8713	M8	212	8,70	13,00	1,00
03.0300.0060	03.0380.0013	M8	213	8,70	14,00	1,00
03.0300.0067		M8	214	8,70	16,00	1,00
03.0300.0093		M8.5	215	9,30	13,30	1,00
03.0300.3006		M10	216	10,35	16,00	2,00
03.0300.0110	03.0380.0107	M10	217	10,70	16,00	1,50
03.0300.0105		M12	218	10,70	18,00	1,50
03.0300.0114		M11	219	11,40	16,30	1,50
03.0300.0125		M11	221	11,80	19,10	1,50
03.0300.0130	03.0380.1271	M12	222	12,70	18,00	1,50
03.0300.0135		M12	223	12,70	20,00	1,50
03.0300.1370		M12	224	13,70	20,00	1,50
03.0300.0142		M13	225	13,70	22,00	1,50
03.0300.0146		M13(13,5)	226	14,00	18,70	1,50
03.0300.0145	03.0380.1472	M14	227	14,70	22,00	1,50
03.0300.3001		M15	228	16,00	22,70	1,50
03.0300.1692	03.0380.1672	M17	229	16,70	24,00	1,50
03.0300.0175	03.0380.1742	M17	230	17,40	24,00	1,50
03.0300.0181		M17(17,5)	231	18,00	24,70	1,50
03.0300.0185		M18	232	18,70	26,00	1,50
03.0300.0195		M20	233	20,70	28,00	1,50
03.0300.0203	03.0380.2152	M21	234	21,50	28,70	2,50
03.0300.2050		M20	235	22,50	28,00	1,50
03.0300.2273		M22	236	22,70	30,00	2,00
03.0300.0207		M22	237	22,70	30,00	3,00
03.0300.2473		M24	238	24,70	32,00	2,00
03.0300.0220		M26	239	26,70	35,00	2,00
03.0300.0230		M27	240	27,20	36,00	2,00
03.0300.0235		M28	241	28,70	37,00	2,00
03.0300.0250		M30	242	31,00	39,00	2,00
03.0300.3374	03.0380.0337	M33	243	33,70	42,00	2,00
03.0300.0266		M33	244	34,30	43,00	2,00
03.0300.0272	03.0380.3670	M36	245	36,70	46,00	2,00
03.0300.3940		M39	246	40,00	51,00	2,50
03.0300.0290		M42	247	42,70	53,00	3,00
03.0300.0294		M48	248	48,70	59,00	3,00
03.0300.0296		M48	249	52,00	60,00	3,00
03.0300.3003		M52	250	53,30	64,50	3,00
03.0300.0089		M88	254	89,09	101,48	3,20
03.0300.3675		M3	301	3,60	7,50	1,00



NBR 80	FKM 80	M	类型	d	D	S
03.0300.0654	03.0380.0004	M5	302	4,60	9,00	1,00
03.0300.5610		M5	303	5,60	10,00	1,00
03.0300.6611	03.0380.6611	M6	304	6,60	11,00	1,00
03.0300.0070		M6	305	6,85	13,27	1,30
03.0300.0071		M6	306	7,00	11,40	1,00
03.0300.0086	03.0380.8613	M8	307	8,60	13,00	1,00
03.0300.0107	03.0380.0007	M10	310	10,70	17,00	1,50
03.0300.0126		M11	312	11,80	18,10	1,50
03.0300.1271	03.0380.0012	M12	313	12,70	19,00	1,50
03.0300.0137		M13	315	13,80	20,10	1,50
03.0300.1472	03.0380.0147	M14	316	14,70	21,00	1,50
03.0300.0165		M16	317	16,70	23,00	1,50
03.0300.0128		M18	320	18,70	27,00	2,00
03.0300.3007		M20	321	20,70	29,00	2,00
03.0300.2173		M22	323	21,70	30,00	2,00
03.0300.0205	03.0380.0227	M22	324	22,70	31,00	2,00
03.0300.2373		M24	325	23,70	32,00	2,00
03.0300.0215		M24	326	24,70	33,00	2,00
03.0300.2735		M26	327	27,00	35,30	2,00
03.0300.2773		M27	328	27,70	36,00	2,00
03.0300.2863		M27	329	28,60	36,00	2,00
03.0300.0240		M28 (28,5)	330	29,20	37,50	2,00
03.0300.0251		M30	331	30,70	39,00	2,00
03.0300.3637		M36	333	37,00	48,00	2,50
03.0300.4243		M42	335	43,00	54,00	2,50
03.0300.4546		M45	336	46,00	57,00	2,50
03.0300.4849		M48	337	49,00	60,00	2,50
03.0300.0101		M1/8"	510	10,40	14,70	1,20
03.0300.0138		M13.5"	511	13,85	18,70	1,20
03.0300.0171		M3/8"	512	17,35	22,70	1,20
03.0300.0204		M1/2"	513	21,65	26,70	1,20
03.0300.2783		M3/4"	514	27,30	32,50	1,20
03.0300.4284		M1 1/4"	516	42,80	49,50	2,00
03.0300.4875		M1 1/2"	517	48,70	55,50	2,00
03.0300.6056		M2"	518	60,50	68,50	2,00
				127,00	143,67	5,20
				155,00	181,00	8,20
				200,00	240,00	9,00

非详尽清单，Techné提供所有特殊的英制尺寸。



## ✓ TBS自定心系列

NBR 或 FKM 橡胶 80±5 IRHD, DC01 - 270级的钢圈, 根据客户要求, 其他的材质也可供选择。

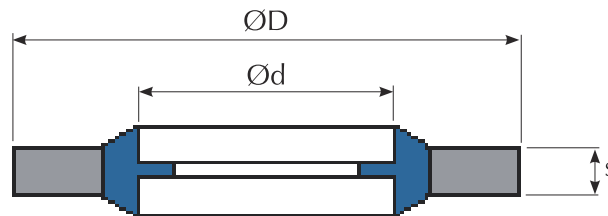

### 英制尺寸

NBR 80	BSP	螺栓	类型	d	D	S
03.0400.8311		5/16	006	8,31	13,34	1,20
03.0400.1037	1/8	3/8	820	10,37	15,88	2,00
03.0400.1374	1/4	1/2	821	13,74	20,57	2,00
03.0400.1651		5/8	869	16,51	25,40	2,00
03.0400.3000		3/8	823	17,28	23,80	2,00
03.0400.1816		11/16	871	18,16	25,40	2,50
03.0400.2154	1/2	13/16	825	21,54	28,58	2,50

### 公制尺寸

NBR 80	M	类型	d	D	S
03.0400.4691	M4	202	4,50	7,00	1,00
03.0400.0056	M5	303	5,60	10,00	1,00
03.0400.6710	M6	206	6,70	10,00	1,00
03.0400.0015	M6	207	6,70	11,00	1,00
03.0400.8713	M8	212	8,70	13,00	1,00
03.0400.0087	M8	866	8,70	14,00	1,00
03.0400.1070	M10	708	10,70	16,00	1,50
03.0400.0107	M10	310	10,70	17,00	1,50
03.0400.0127	M12	867	12,70	19,00	1,50
03.0400.1418	M13,5	226	14,00	18,70	1,50
03.0400.0014	M14	316	14,70	21,00	1,50
03.0400.0147	M14	227	14,70	22,00	1,50
03.0400.0016	M16	317	16,70	23,00	2,00
03.0400.0167	M16	870	16,70	24,00	1,50
03.0400.0187	M18	872	18,70	26,00	1,50
03.0400.0207	M20	873	20,70	28,00	1,50
03.0400.0018	M22	874	22,70	30,00	2,00

非详尽清单, Techné提供所有特殊的英制尺寸。

## ✓ KDS系列

NBR 或 FKM 橡胶 80±5 IRHD, DC01 - 270级的钢圈, 根据客户要求, 其他材质也可供选择。

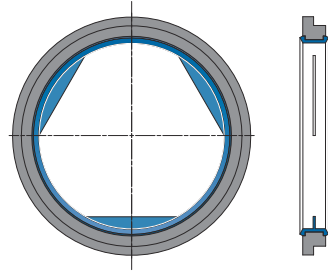

KDS

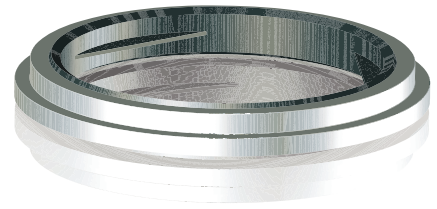

17

Part No.	ID	OD	Height
KDS10	10.2	16.0	3.0
KDS12	12.2	18.0	3.6
KDS14	14.2	20.0	3.6
KDS16	16.9	24.0	3.6
KDS18	18.2	23.9	3.6
KDS22	22.2	30.0	5.1
KDS26	26.2	35.0	4.1
KDS27	27.2	38.0	4.1
KDS30	30.2	40.0	4.3
KDS33	33.5	42.0	4.3
KDS42	42.3	49.9	4.4
KDS48	48.3	60.0	4.4

非详尽清单, Techné提供所有特殊的英制尺寸。





液压密封件



机加工密封件



表面处理



Techné简介



滑动轴承

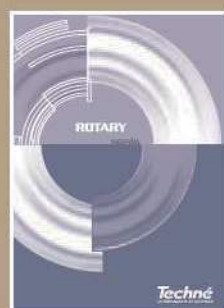

旋转密封件

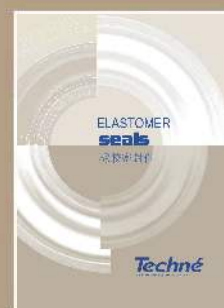

橡胶密封件



卫生级密封件

# Techné

泰克尼尔密封件贸易（上海）有限公司  
上海市闵行区中春路7755号  
宝虹中心208室（201101）  
电话：021-64738417 传真：021-64738439

## OEM

Tel: +33 (0) 4 78 43 12 72  
Fax: +33 (0) 4 78 43 12 77  
E-mail: oem@techne.fr

## Industrie

Tel: +33 (0) 4 78 43 78 78  
Fax: +33 (0) 4 78 43 16 91  
E-mail: industrie@techne.fr

## Distribution

Tel: +33 (0) 4 78 43 12 70  
Fax: +33 (0) 4 78 43 11 43  
E-mail: distribution@techne.fr

## Chromex

Tel: +33 (0) 1 69 92 16 30  
Fax: +33 (0) 1 64 94 84 02  
E-mail: chromex@chromex.info

## Techné Shanghai

Tel: +86 21 64 73 84 17  
Fax: +86 21 64 73 84 39  
E-mail: techneshanghai@techne.cn

## Techné Turquie

Tel: +90 (0) 212 256 68 96  
Fax: +90 (0) 212 255 58 15  
E-mail: turkey@techne.fr



**techne.fr**

